

Parallel Torque Arms

Features/Benefits

- Air Bias Support System Air Adjustment by mini-regulator with air cylinder, for proper positioning of different size tools. Eliminates the clumsy spring adjustment of competitive models. Tool positioning is effortless.
- Parallel Arm Torque Absorber Absorbs torque reaction up to 120 in. lbs. Increases torque repeatability through shift changes by reducing operator influence on fastener. Keeps tools off the floor.
- Steel & Aluminum Construction Anodized finish Lightweight Heavy duty for high volume production Corrosion resistant.
- Auto-Orientation System Tool fixture is designed to allow constant perpendicular orientation of the tool, which ensures proper fastener alignment.



IRBP3-N30



IRBP3-E30

Accessories

- 48732-1 Bench clamp for mounting arm in place
- C10-02-000 Filter/Lubricator (1/4")
- R00-02-G00 Regulator (1/4")
- IR49541 Swivel Mount Kit Grip and Angle Tools (adapts pistol to the workstation)

Parallel Torque Arms			
Model no.	Length (in.)	Tool use	Torque absorber
IRBP3-N30	30	Air	Yes
IRBP3-E30	30	Electric	Yes

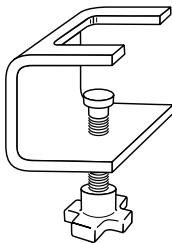

48732-1

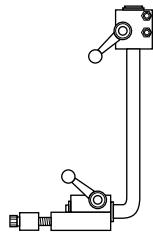

IR49541



Filter/Regulator (1/4 in.)
B18-02-FKG0-28



Lubricator (1/4 in.)
L18-02-LK00-28

Dimensions

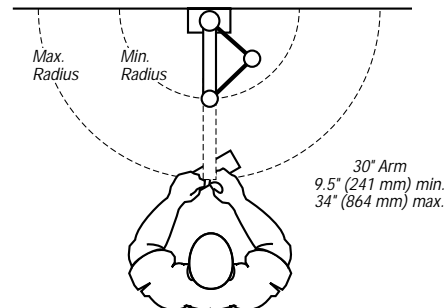
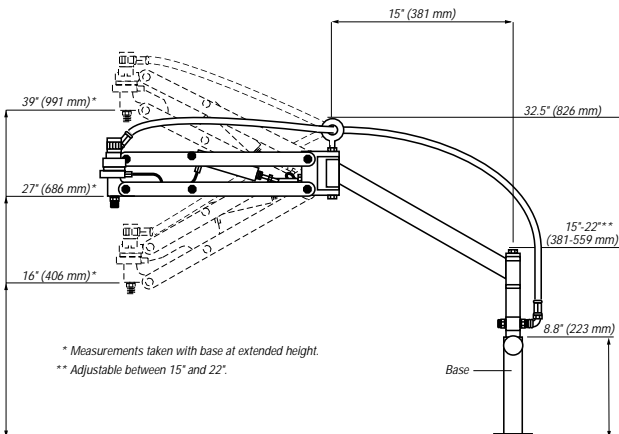

Features/Benefits

- Steel Construction: E-Coat Lightweight but durable for continuous duty. Corrosion Resistant.
- Flexible: Your choice of 30" or 24" lengths for electric or air tools.
- Balancer Hanger: All arms are equipped with a roller mounted balancer hanger for smooth motion of the tool.
- Electric Cord Clamp Kit: Standard with appropriate models.

Options

- Single Arm Torque Absorber: Telescoping torque arm improves flexibility. Eliminates torque reaction from the tool.

Accessories

- Balancers – Choice of balancers
7/8 to 2-1/4 lbs Bld 1
2 to 4 lbs = Bld 2
4 to 6 lbs = Bld 3
- 48732-1 Bench clamp for mounting arm in place
- C10-02-000 Filter/Lubricator (1/4")
- R00-02-G00 Regulator (1/4")



IRBS3-N30 (Hose, FRL and balancer not included)



IRBS3-E0

Parallel Torque Arms			
Model no.	Length (in.)	Tool use	Torque absorber
IRBS2-N0	24	Air	No
IRBS2-N24	24	Air	Yes
IRBS2-E0	24	Electric	No
IRBS2-N24	24	Electric	Yes
IRBS3-N0	30	Air	No
IRBS3-N30	30	Air	Yes
IRBS3-E0	30	Electric	No
IRBS3-E30	30	Electric	Yes

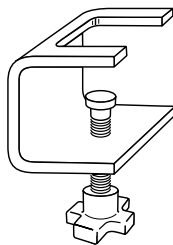

48732-1

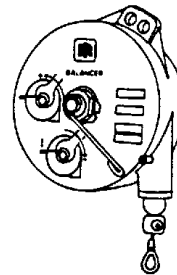

IRAX Balancer



Filter/Regulator (1/4 in.)
B18-02-FKG0-28



Lubricator (1/4 in.)
L18-02-LK00-28

Dimensions

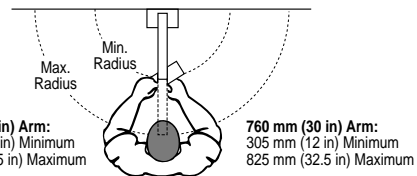
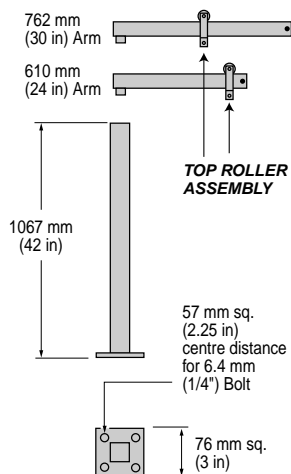

Beam Clamp

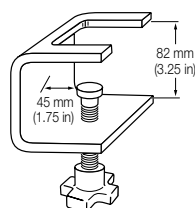

Electric Tool Clamp

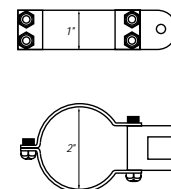

EZ Tool Articulating Arm

EZ tool arm features:

- Covers a 610 x 762 mm (24 x 30 inch) horizontal rectangular work envelope.
- Two piece arm with overall length adjustable from 864 to 1067 mm (34 to 42 inches).
- Anodized aluminum construction.
- Mounting plates attach vertically or horizontally.
- First portion of the arm consists of two adjustable sections connected to the mounting plate by a 360 degree pivot.
- Second, outer portion of the arm is a dual parallel arm design that allows for 500 mm (20 inches) of vertical travel, and is connected to the first portion by a 360 degree pivot.

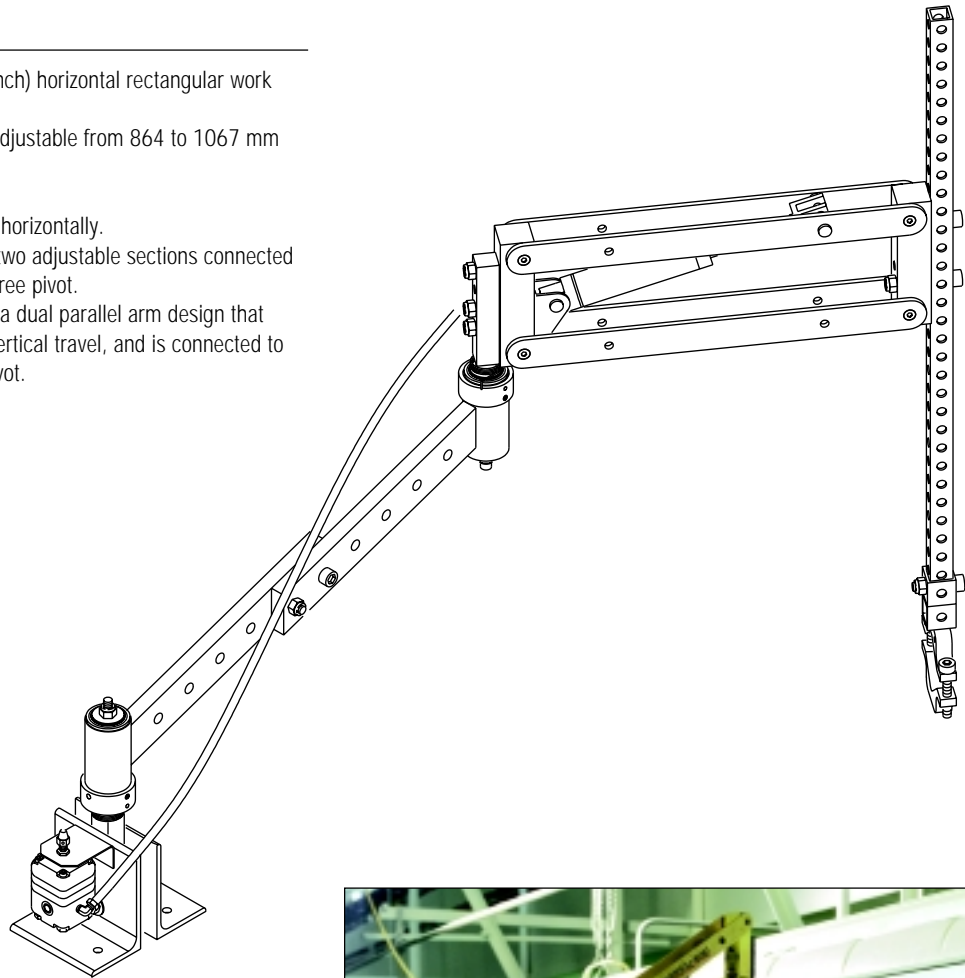

Additional features:

- Each pivot contains roller bearings for smooth operation and an adjustable pivot spring to return the arm to a "home" position.
- Capacity is 13.6 kg (30 lb) at 7 bar (100 psi).
- Pneumatics control system consists of a single precision pneumatic regulator to allow balance of the end of the arm. Maximum torque reaction is 80 Nm (60 ft/lb).
- Fixed tool holder to handle tool diameter from 13 to 63.5 mm (.50 to 2.5 inches) is adjustable for vertical or horizontal tool orientation.



EZ Tool Arm in an assembly process

EZ Tool Articulating Arm Specifications

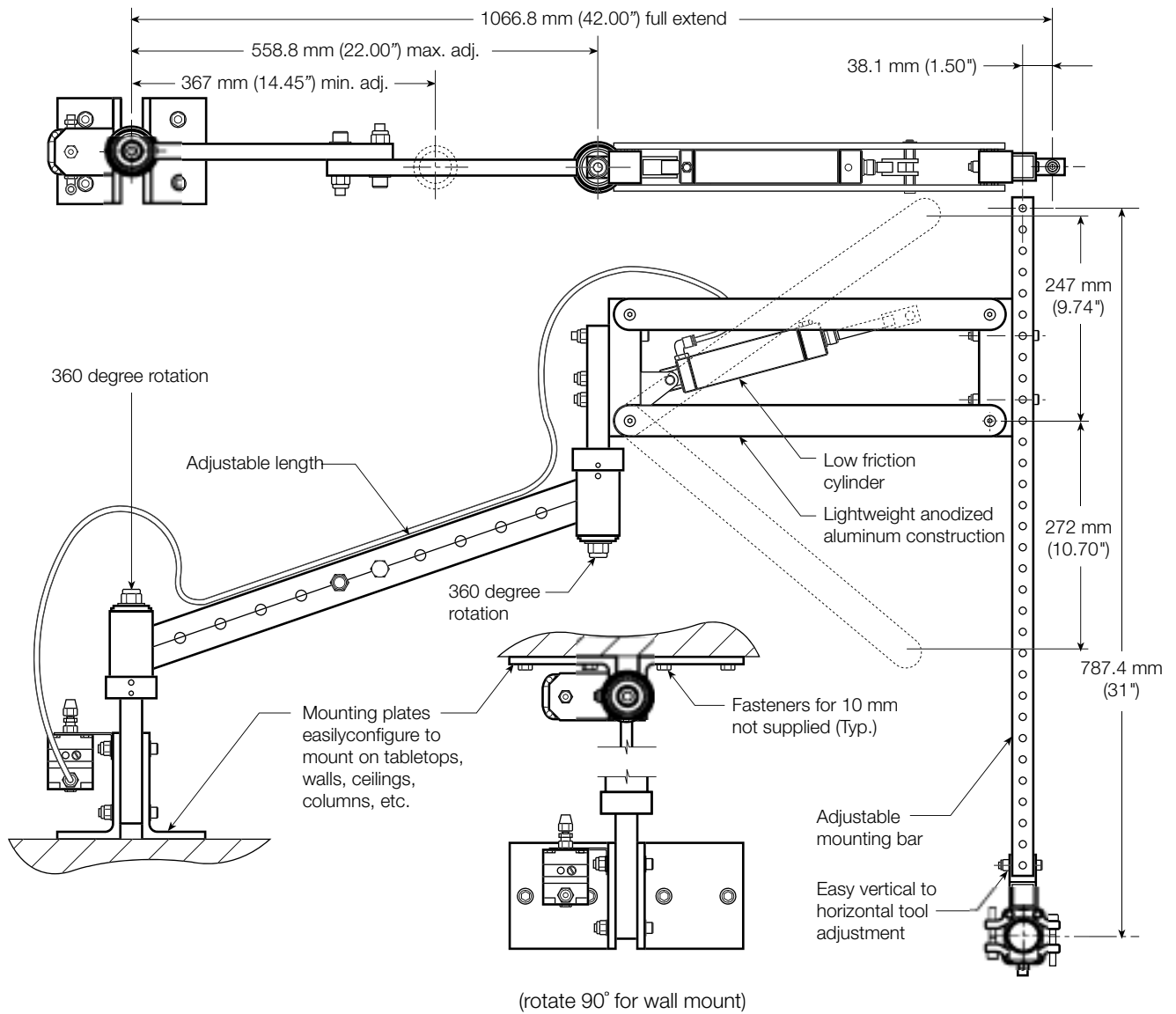

EZ tool arm model number EZTA080500 illustrated



Tool Holders

Part no.	Description
54033162	Bi-Directional tilt / Push to start tool
54033196	Single-Directional tilt tool holder

EZ Tool Arm

Part no.	Description
EZTA080500	Light weight torque arm with tool holder
43146000	Light weight articulating arm without tool holder

E-Z Torque

Just as the name indicates, the new IR Zimmerman E-Z Torque® has taken the struggle out of using hand-held torque tools.

The lightweight E-Z Torque has been coupled with our 50 pound Balancer to provide the most innovative power tool assist system available today. Ease of operation eliminates operator fatigue problems, fights carpal tunnel syndrome and brings added safety to the workstation. E-Z Torque has been engineered to absorb the pounding reaction of air-powered or electric-driven torque tools. Constructed of cast aluminum and steel with ball bearing rollers and a 48 inch (1219.2 mm) vertical travel, the E-Z Torque eliminates spring pull back and maintains tool position with no problem.

Features:

- Lightweight torque tool assist
- Ease of operation
- Reduces operator fatigue
- Aluminum and steel construction
- Adjustable to fit any tool



E-Z Torque shown with optional tool

E-Z Torque	
Part no. complete	Application
EZTQ5060	EZ Torque Tool Balancer
Suspension Kits	
16520	ZRA1 rail
16525	ZRA2 rail
16530	ZRS2/3 rail

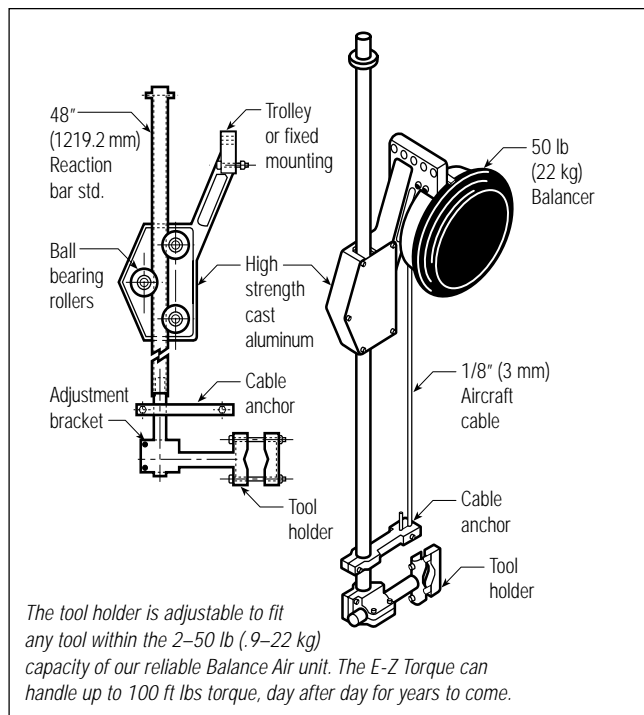

Ergonomic Torque Reaction Products

Torque Tube

We at IR Zimmerman support our tool product line with ergonomic torque reaction and tool suspension products to assist in reducing operator fatigue. Our products relieve the operator of tool weight and torque resulting in productivity. These products also help prevent the long-term damaging effects of torque reaction on the human body, resulting in lower workers compensation and health care costs.

Our torque tubes allow tools to be lifted, lowered, moved and brought into optimum working position with minimal force required by the operator. Whether the products are used alone or integrated into a larger "turnkey" system, the smooth and effortless vertical motion will be the perfect solution for various operators.

The availability of various sizes and the modularity of design allows System Integrators to use individual component parts without having to purchase complete units.

Modular Components

Suspension kit features:

- High strength Delrin wheels
- Cast aluminum or stamped steel trolley bodies
- Sealed bearings
- Low tolerance side guide rollers

Torque tube features:

- 0 - 150 Nm torque capacity
- Modular metric design
- Low friction bearing plates for effortless vertical travel and maintenance-free operation
- 304 stainless steel construction
- 20 kg/44 lb capacity at 7 bar/100 psi
- 300, 600, 900 mm/12, 24, 36 inches of vertical travel

Extension tube features:

- Rugged welded stainless steel construction

Tool holder features:

- Tool holder clamp is 316 stainless steel construction designed to minimize tool damage
- Accepts tools of 19 mm to 63 mm/.75 to 2.5 in. diameter
- Switches easily from horizontal to vertical orientation
- 360 degree tool holder features:
 - Generous 66.8 mm/2.63 in. opening insures that tool head does not have to be removed for quick changes
 - Bronze bushing provides easy rotation and durability
 - Rotates freely through 360 degrees or locks at 45 degree increments with indexing plunger

Air cylinder features:

- Low friction cylinders
- High flow regulator

Tool air supply features:

- Precoil hoses
- Bulkhead fittings

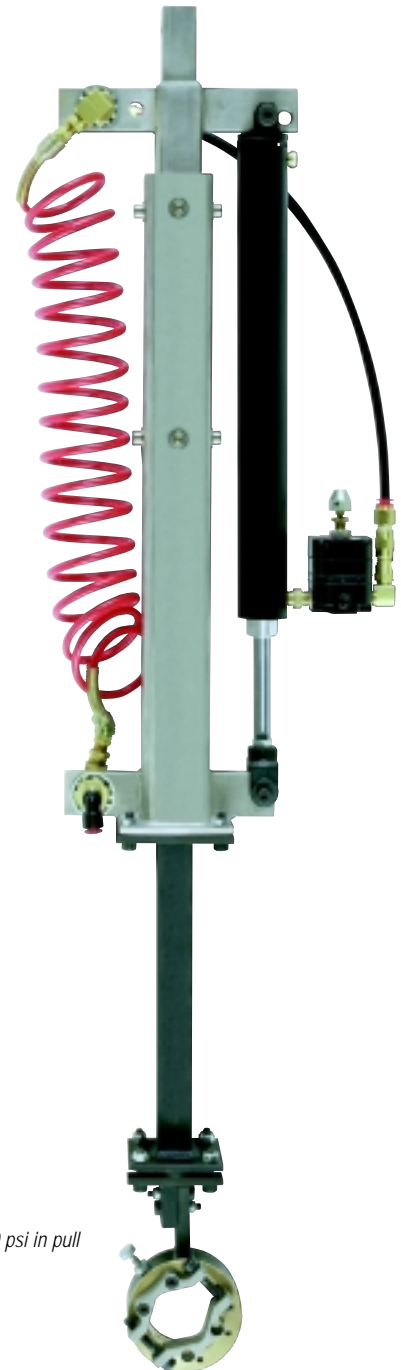

*1.5 inch bore cylinder @ 100 psi in pull
with lift, 100 lbs/45 kg*

Torque Tube Components

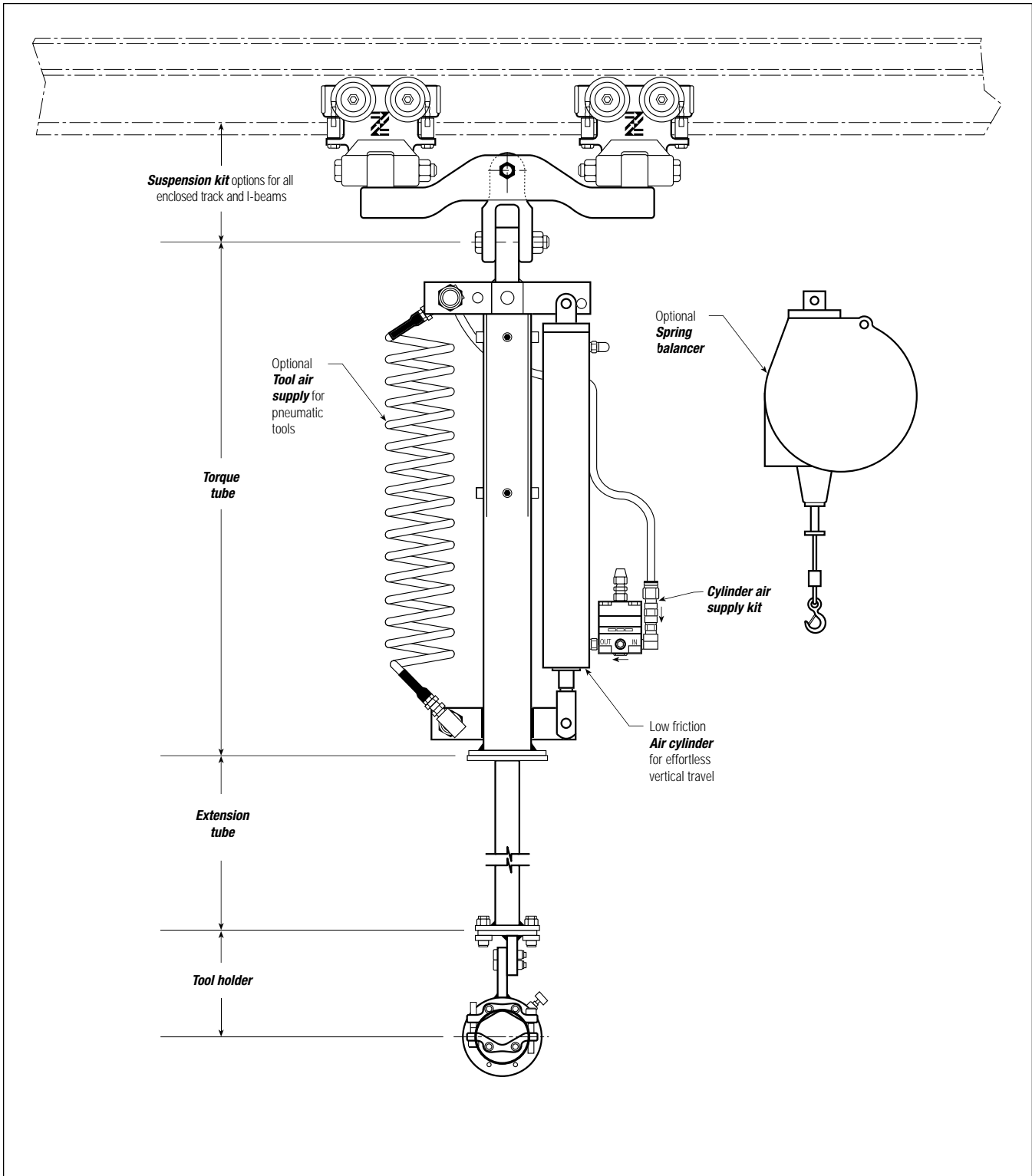

Torque Tube Component Specifications



Suspension kit features:

- High strength Delrin wheels
- Cast aluminum or stamped steel trolley bodies
- Sealed bearings
- Special low tolerance side guide rollers

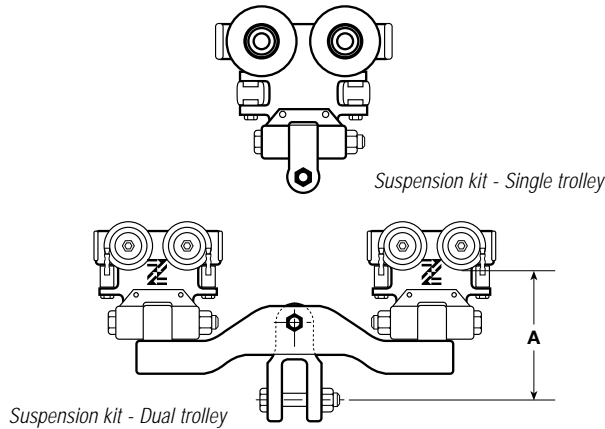

Torque tube features:

- Low friction bearing plates for effortless vertical travel and maintenance-free operation
- stainless steel construction
- Modular metric worldwide design

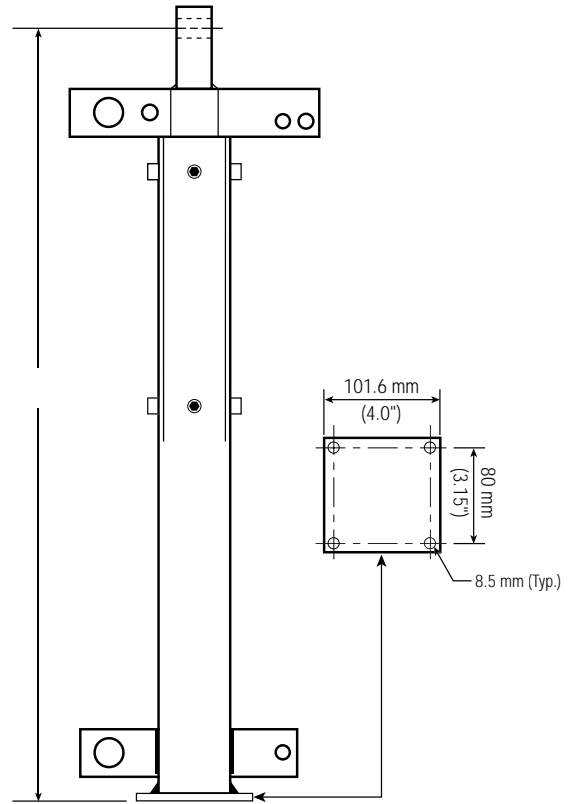

Suspension Kits – Single and Dual Trolleys

Model no. Dual trolley ⁽¹⁾	Part No.	"A" dimension		Weight	
		in.	mm	lbs	kg
Single					
ZRA2	16610	4.75	120	4.50	2
ZRAS2/3	16600	4.75	120	4.50	2
KBK-II/III	16615	4.75	120	4.50	2
ETA-8	16635	4.75	120	4.50	2
T-Rail	16620	3	76.2	15	6.8
Dual					
ZRAT	16755	6.48	165.0	10.50	4.76
ZRA1	16705	6.13	156.0	10.50	4.76
ZRA2	16710	6.76	172.0	10.50	4.76
ZRAS2/3	16700	6.76	172.0	10.50	4.76
KBK-I	16725	6.13	156.0	10.50	4.76
KBK-II/III	16715	6.76	172.0	10.50	4.76
ETA-4	16744	6.13	156.0	10.50	4.76
ETA-8	16735	6.76	172.0	10.50	4.76
Gorbel	16707	6.13	156.0	10.50	4.76
T-Rail	16620	3.00	76.2	15.00	6.8

Torque Tubes

Part no.	Vertical travel		"B" extended		"B" retracted	
	in.	mm	in.	mm	in.	mm
EZTT150300	12	300	38.5	978	26.5	673
EZTT150600	24	600	62.5	1588	38.5	978
EZTT150900	36	900	86.5	2197	50.5	1283

Tool air supply features:

- Precoil hoses
- Bulkhead fittings



Torque Tubes

Part no.	Weight of lower portion		Total weight	
	lbs	kg	lbs	kg
EZTT150300	9.8	4.43	20.9	9.5
EZTT150600	14.6	6.6	28.2	12.8
EZTT150900	19.2	8.77	30.5	16.1

Tool Air Supply

Part no.	Description
90014	Tool air supply package 1/4 inch
90012	Tool air supply package 1/2 inch

Torque Tube Component Specifications



Extension tube features:

- Tubes are rugged stainless steel construction
- Welded construction

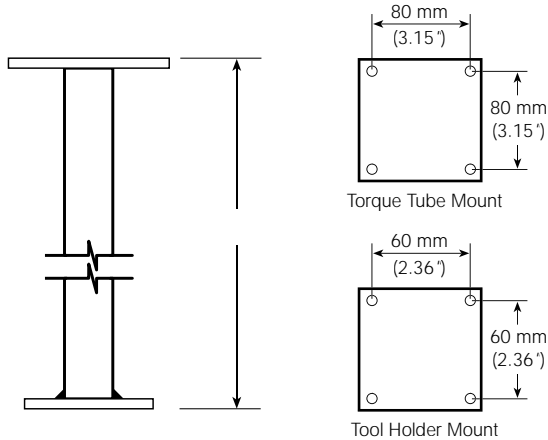

Extension Tubes					
Part no.	"C" dimension		Weight		
	in.	mm	lbs	kg	
ET150	6	150	2.6	1.2	
ET300	12	300	3.4	1.8	
ET450	18	450	5.1	2.3	
ET600	24	600	6.3	2.9	
ET750	30	750	7.5	3.4	
ET900	33	900	8.7	3.9	

Tool holder features:

- Fixed tool holder.
- Accepts tools of 13 to 63 mm (.50 to 2.5 inch) diameter.
- Tool holder easily changes from horizontal to vertical
- 360 degree tool holder has generous 66.8 mm (2.63 inch) opening so that the tool head does not have to be removed for quick changes.
- 360° holder has a bronze bushing for easy rotation and long life.
- 360 degree tool holder can spin freely or can be locked every 45° when the index plunger is engaged.

Tool Holders					
Part no.	Description	"D" dimension		Weight	
		in.	mm	lbs	kg
52000	Fixed (2 axis) horiz./vertical	4.82	122	2.30	.90
52100	360 degree (3 axis) swivel	5.38	136.7	5.00	2.27

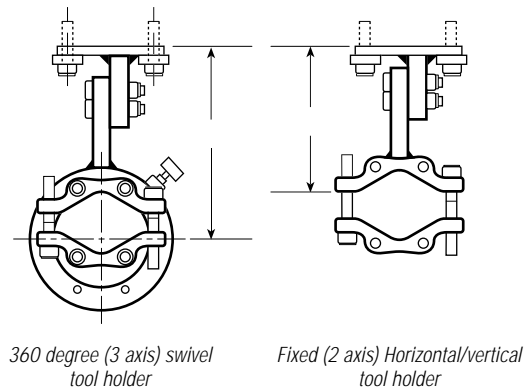

360 degree (3 axis) swivel tool holder

Fixed (2 axis) Horizontal/vertical tool holder

Note:
If a tool holder is ordered,
an extension tube must be ordered

Air cylinder features:

- Low friction cylinders
- High flow regulator
- Air cylinder includes cylinder, rear clevis and rod end clevis

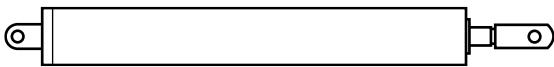

Air Cylinder ¹					
Part no.	Vertical travel		Weight		
	in.	mm	lbs	kg	
63001	11.8	300	5.00	2.27	
66001	23.6	600	6.96	3.16	
69001	35.4	900	11.00	4.99	

Note:
(1) Air filters come standard with regulators.

Cylinder Air Supply	
Part no.	Description
90050	Cylinder air supply package

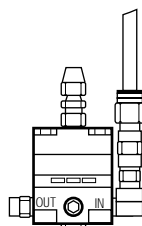

IRAX spring balancers:

To determine model of balancer, add weights of lower portion of torque tube, extension tube, tool holder and tool.

IRAX Spring Balancer					
Part no.	Capacity		Weight		
	lbs	kg	lbs	kg	
BMDL-6	8.8 – 13.2	4 – 6	7.1	3.2	
BMDL-8	13.2 – 17.6	6 – 8	7.7	3.5	
BMDL-10	17.6 – 22.0	8 – 10	8.2	3.7	
BIDS-15	22 – 33	10 – 15	16.5	7.5	
BIDS-20	33 – 44	15 – 20	17.0	7.7	
BIDS-25	44 – 55	20 – 25	17.2	7.8	

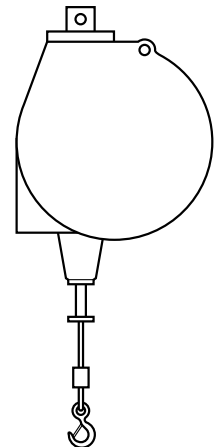

Heavy duty tool arm features:

- Lightweight, anodized aluminum construction.
- Modular metric design.
- 150 nm (110 ft/lb) of torque reaction.
- 50 kg/110 lb of capacity at 2 m/6.5 ft with 7 bar/100 psi.
- 500 mm/20 inches of vertical travel.
- Externally mounted sealed and lubricated roller bearings.
- Pneumatics control system consists of a single precision pneumatic regulator to allow balance at the end of the arm.
- Numerous mounting configurations.

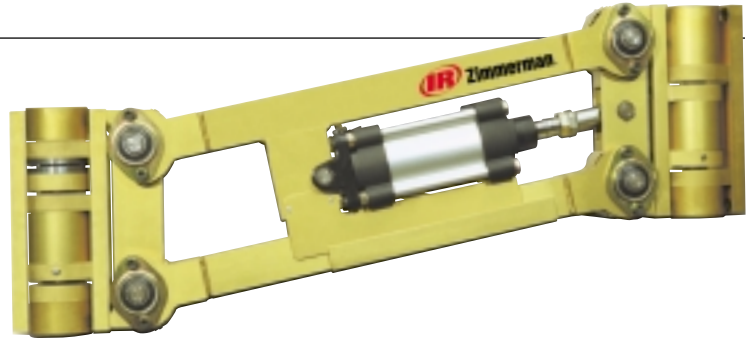

Options:

- Multiple tool holders and extension tubes (see torque tube component specifications for tool holders and extension tubes available).
- Optional pivot provides up to 220 degrees of rotation and includes adjustable stops to limit rotation.
- Optional locking pivot brake renders arm rigid to absorb torque.

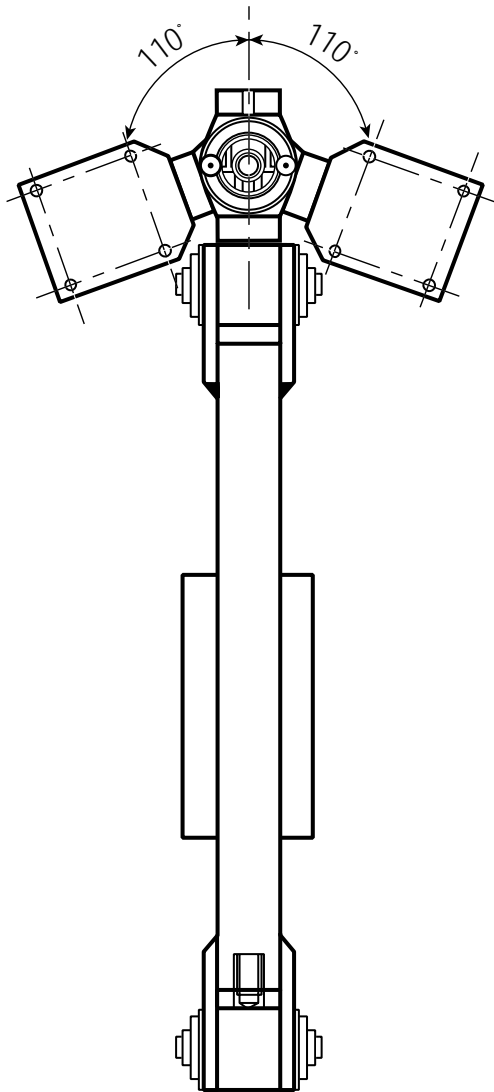

Top view of medium duty tool arm showing 220 degree rotation

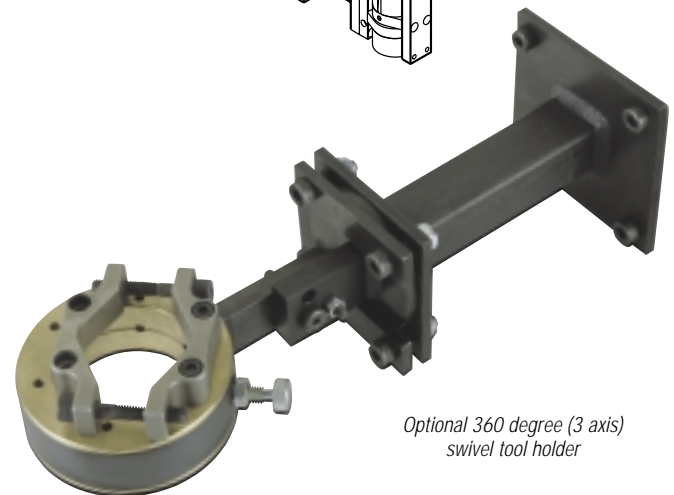
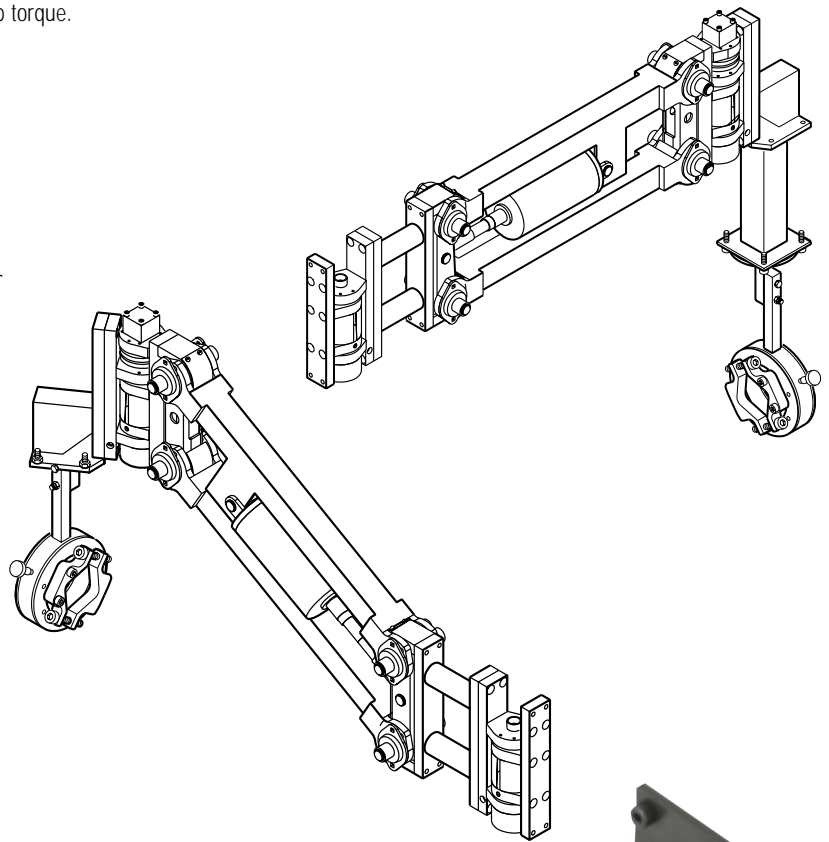

Optional 360 degree (3 axis) swivel tool holder

Heavy Duty Tool Arm Specifications

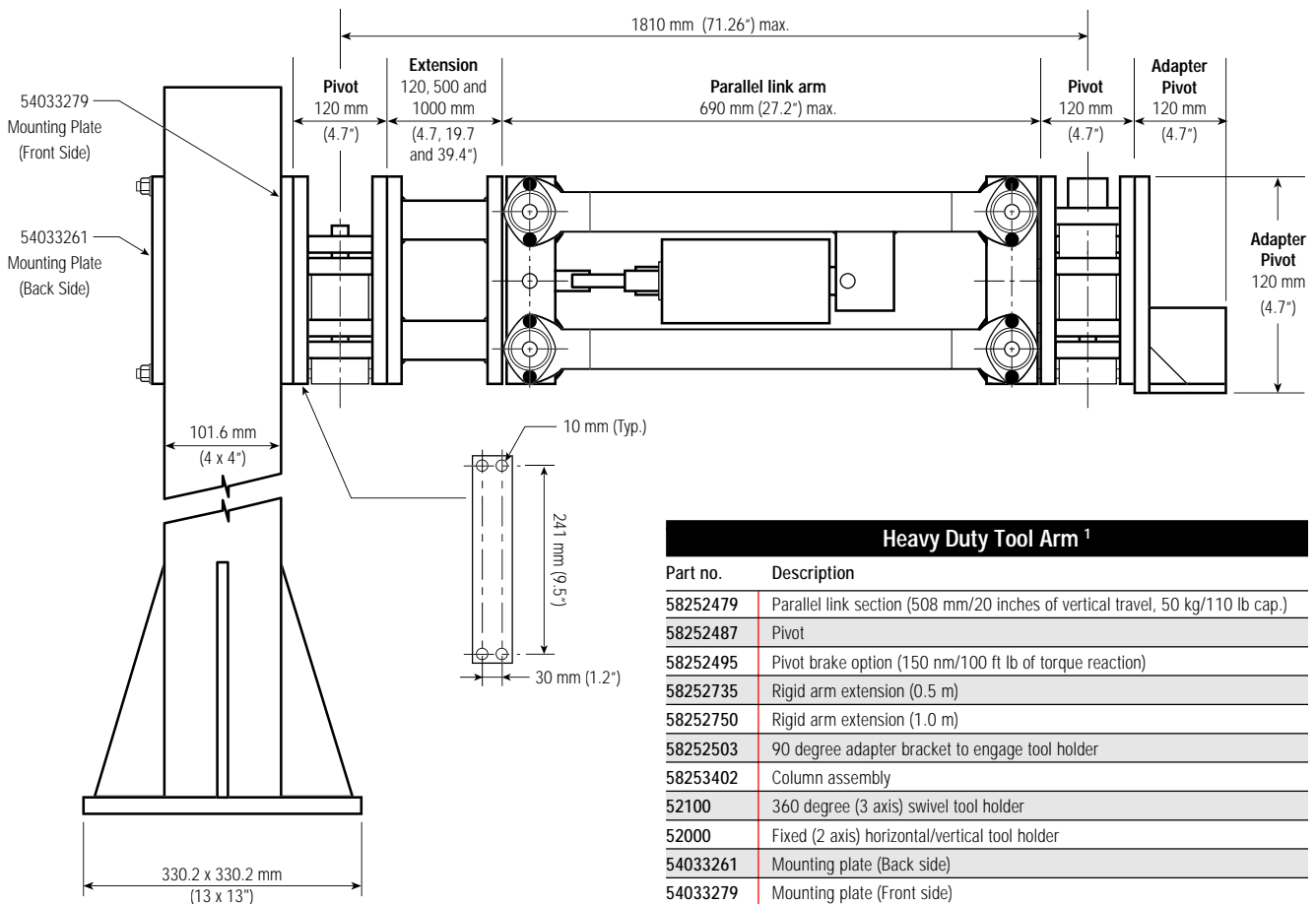
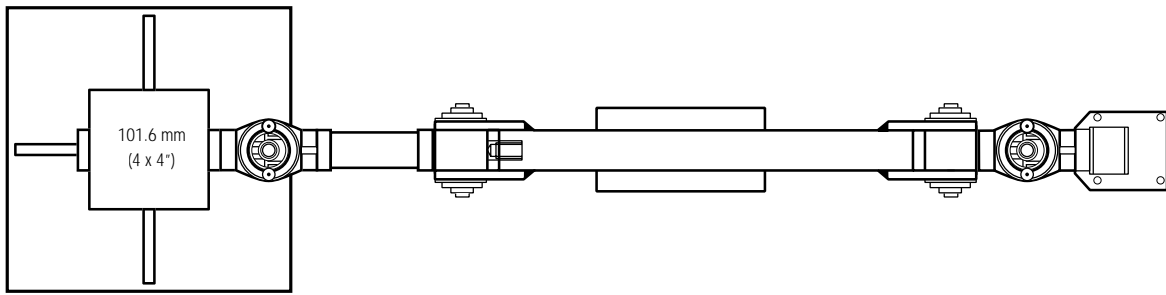

Heavy Duty Tool Arm ¹	
Part no.	Description
58252479	Parallel link section (508 mm/20 inches of vertical travel, 50 kg/110 lb cap.)
58252487	Pivot
58252495	Pivot brake option (150 nm/100 ft lb of torque reaction)
58252735	Rigid arm extension (0.5 m)
58252750	Rigid arm extension (1.0 m)
58252503	90 degree adapter bracket to engage tool holder
58253402	Column assembly
52100	360 degree (3 axis) swivel tool holder
52000	Fixed (2 axis) horizontal/vertical tool holder
54033261	Mounting plate (Back side)
54033279	Mounting plate (Front side)
54036009	Column

Note:
Standard column is 10 ft high. Please specify cut down lengths while ordering, if different height is desired.

Control packages, pivot brake option and cylinder control packages available on request.

Max weight capacity is 100 lbs (45.36 kg)

Max torque reaction is 150 Nm (110 ft lbs)

Note:
(1) Call Customer Service for control options.



Ontario's Largest
Pneumatic & Hydraulic Tool Distributor

1-2430 Lucknow Drive, Mississauga, Ontario L5S 1V3. Tel: 905-672-5557 Fax: 905-672-5559
Email: sales@dobcoeqp.com www.dobcoeqp.com